

GRAPHIC DESIGN PROGRAM UNIVERSITY OF THE INCARNATE WORD

BFA PORTFOLIO REVIEW

The aim of the Graphic Design program is to prepare students for a demanding and competitive profession. Dedication to this goal means that the program must be selective in quantity in order to offer the best quality opportunity that we can.

Because the Graphic Design program requires a specific set of skills, all students planning on entering the Graphic Design Program must submit a portfolio for review in order to be admitted.

Portfolios will be reviewed at the end of the Foundations year.

Transfer students who wish to start in the program classes must year r B year ecauf

Portfolio Case

Mounted Boards from:

- Foundations of Design
- Graphic Design Software
- Digital Imaging*
- Typography I*

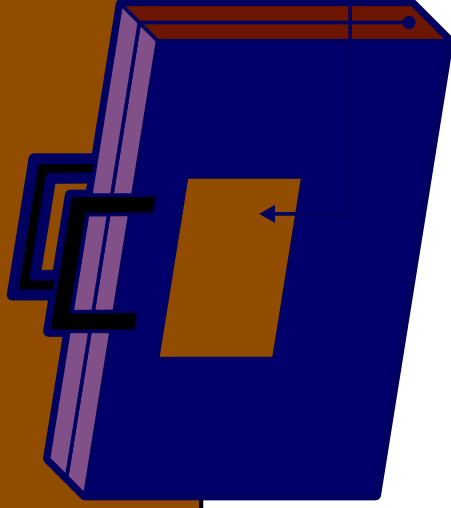

Reusable Bag

Binders, Envelopes, and Portfolio Book from:

- Foundations of Design
- Graphic Design Software & Digital Imaging
- Typography I*
- Drawing for Designers*

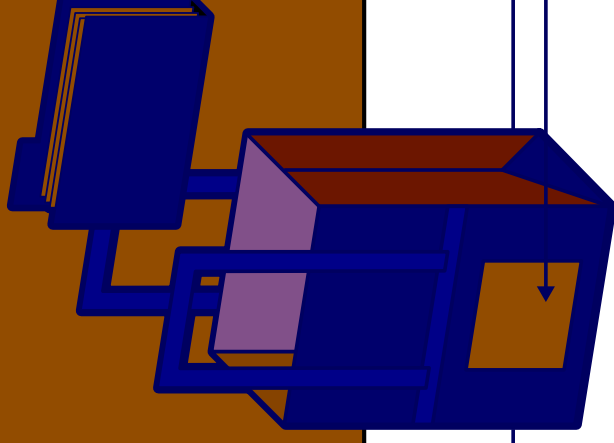

Folder

Please include:

- Portfolio Review Application
- Current Transcript (Unofficial is okay)

Tube

Large format work from:

- Drawing I
- Digital Imaging



Please label all of the items that you are submitting for the review.

* Work from these classes that was turned in at the end of the semester will be added to your portfolio by the faculty prior to the review.